

Figure 7-3. Installation Drawing – Left Side View – IO-540-C, -D, -J, -N

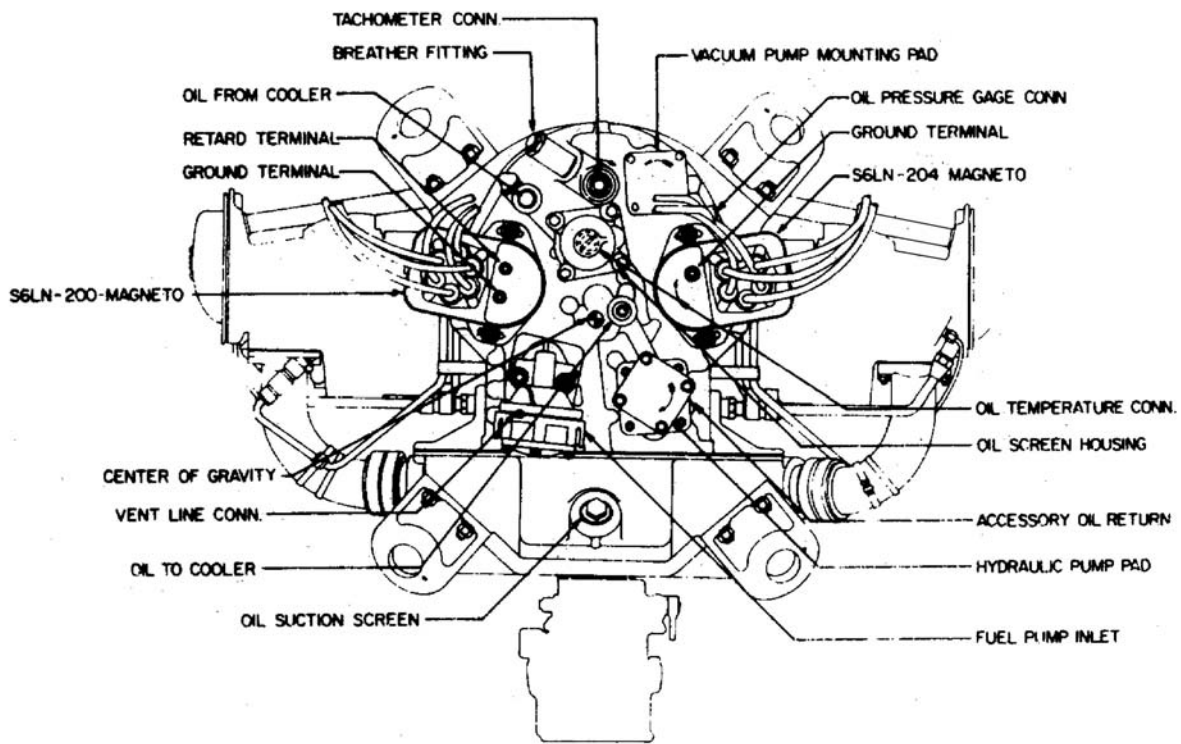

Figure 7-4. Installation Drawing – Rear View – IO-540-C, -D, -J, -N

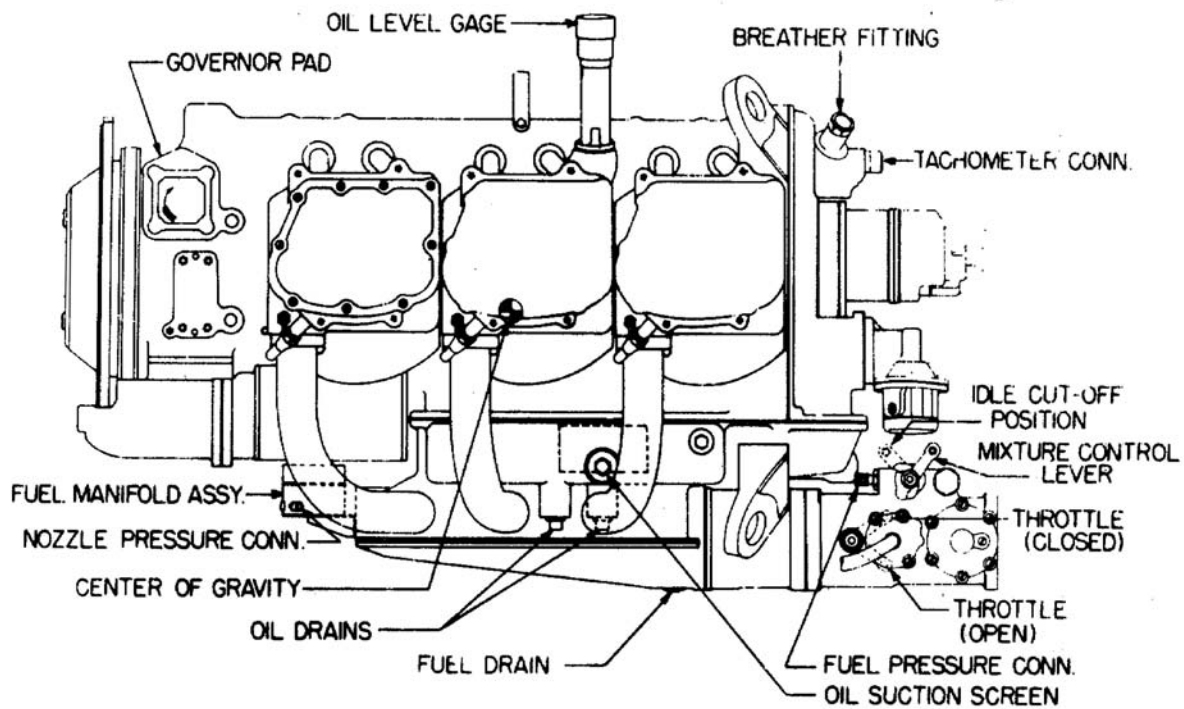

Figure 7-5. Installation Drawing - Left Side View - IO-540-B, -E

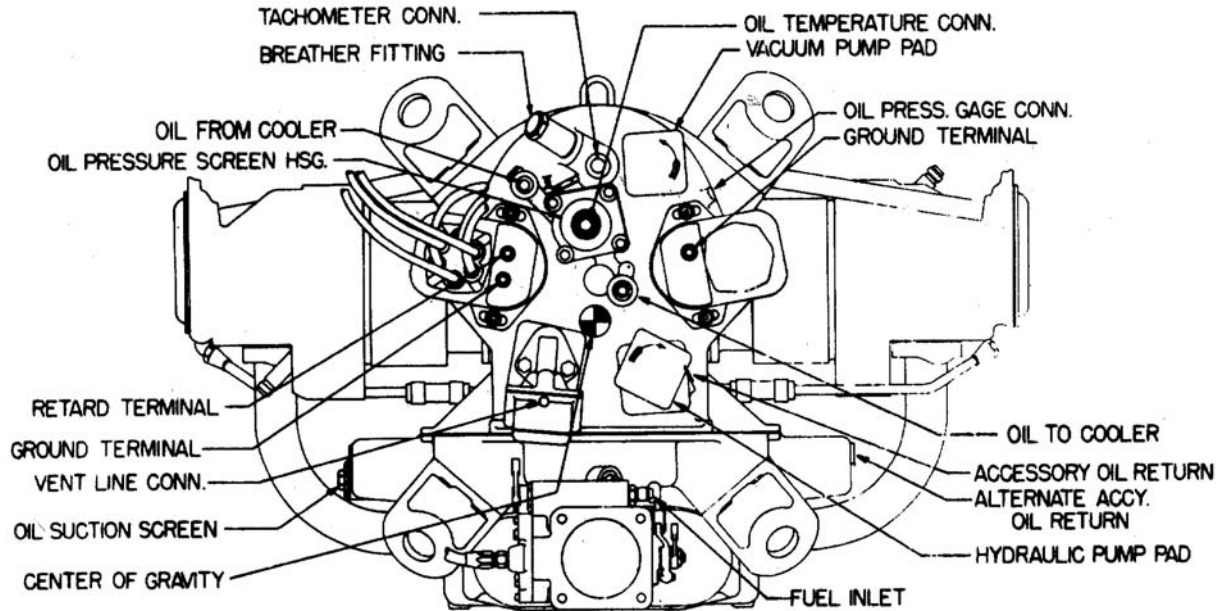

Figure 7-6. Installation Drawing - Rear View - IO-540-B, -E

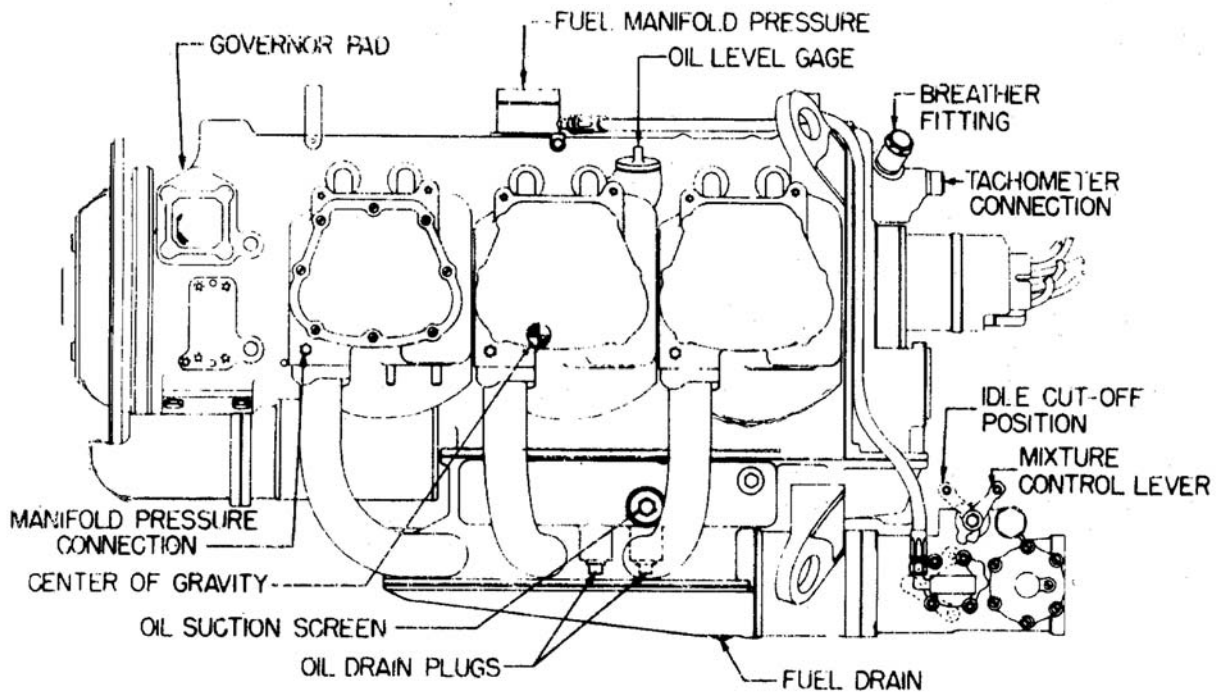

Figure 7-7. Installation Drawing – Left Side View – IO-540-A, -G, -P, -S

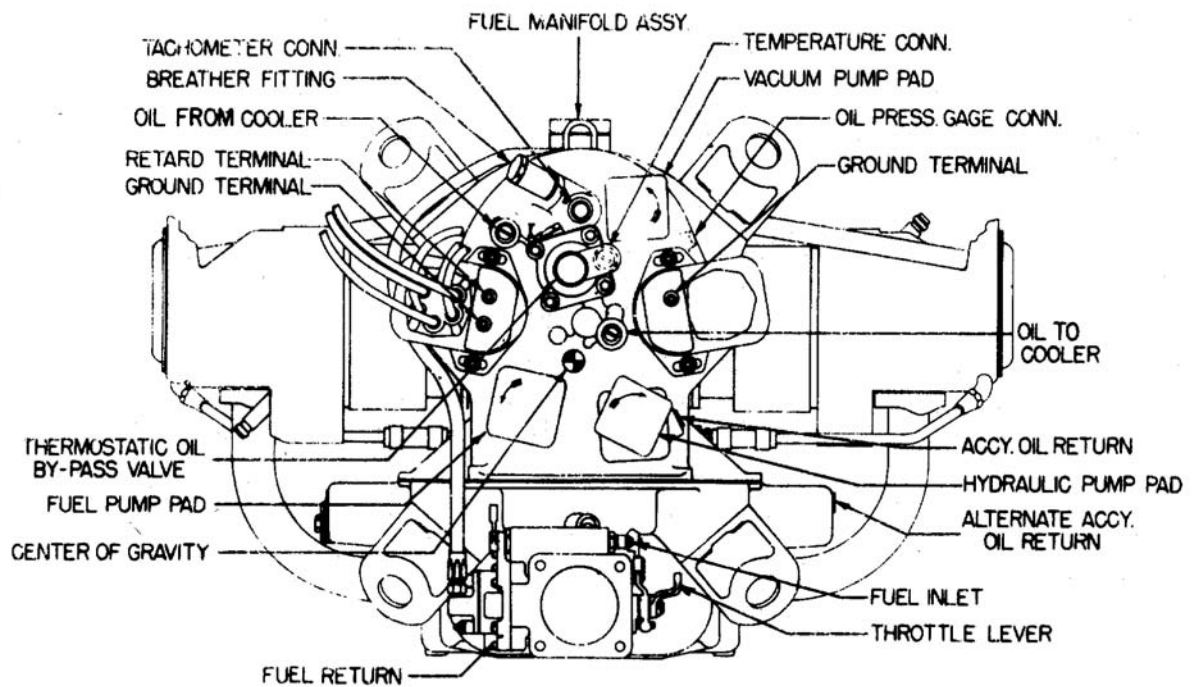

Figure 7-8. Installation Drawing – Rear View – IO-540-A, -G, -P, -S

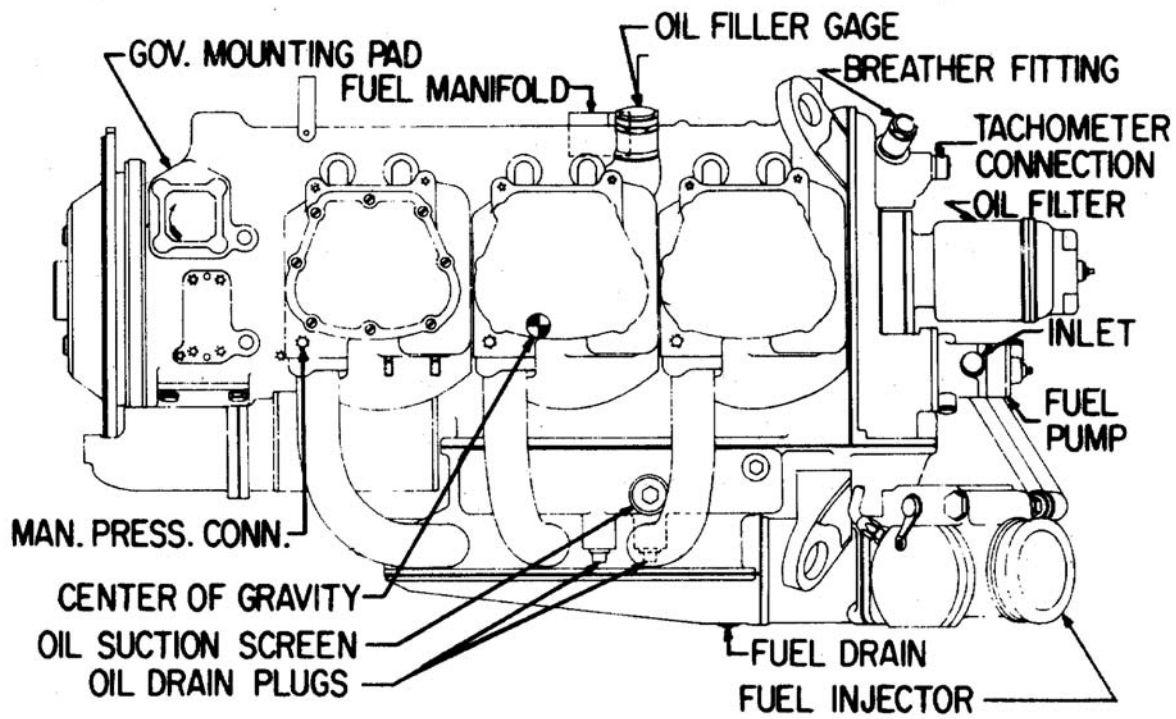

Figure 7-9. Installation Drawing – Left Side View – IO-540-K

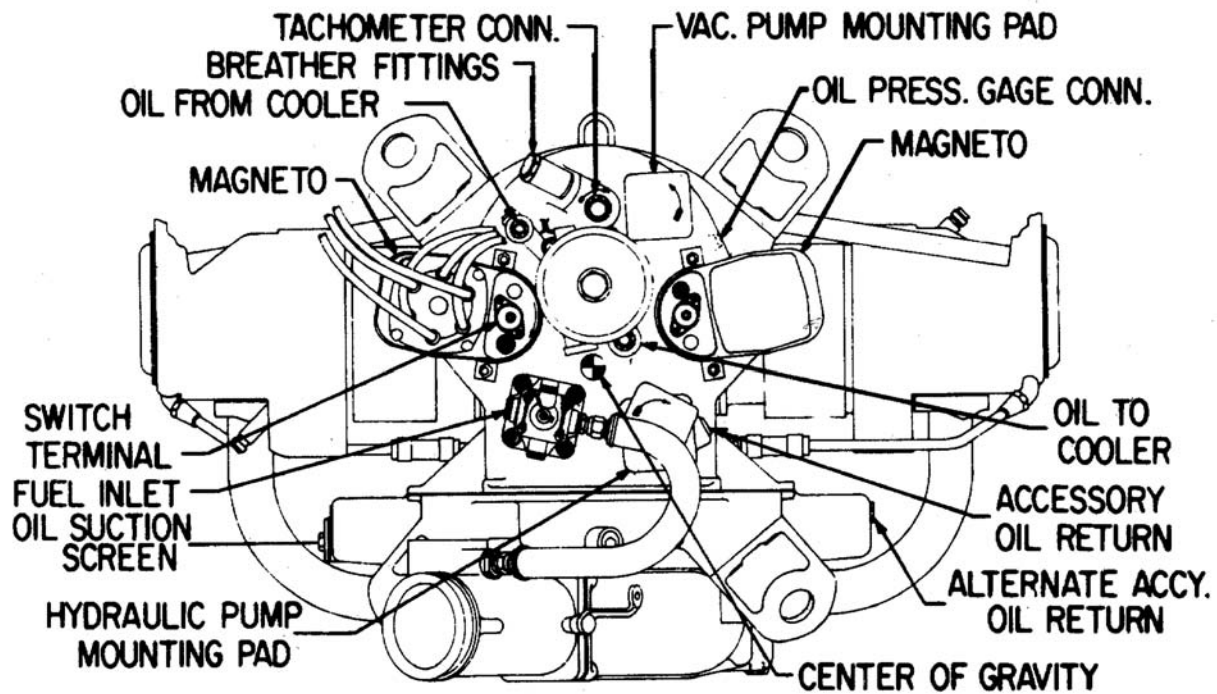

Figure 7-10. Installation Drawing – Rear View – IO-540-K